

ADMIRALTY SIGNAL AND RADAR ESTABLISHMENT

(Was CV151 Green)

Specification AD/CV341/Issue 2. Dated 28.11.49. To be read in conjunction with K1001 ignoring clauses:- 5.2, 5.8.	<u>SECURITY</u>	
	<u>Specn.</u> Restricted	<u>Valve</u> UNCLASSIFIED

<u>TYPE OF VALVE:-</u> Hot Cathode, gas filled grid controlled triode. <u>CATHODE:-</u> Directly heated. <u>ENVELOPE:-</u> Glass. <u>PROTOTYPE:-</u> XGR3.	<u>MARKING</u> See K1001/4. Colour mark as in Fig.1.
--	--

<u>RATING</u>			Note	<u>DIMENSIONS & CONNECTIONS</u>	
Vf	(V)	1.4			
Max. If	(mA)	220		See Fig.1.	
{	Va	(V)	135		A
	Vg striking	(V)	-3.0 to -5.0		B

<u>NOTES</u>	
A.	Applied through 0.1 Megohms.
B.	Applied through 5 Megohms.
C.	Tests 'c', 'd', 'e'. (i) and (ii) are alternative tests. Either one may be used. In test (i) pure D.C. must be used. There must be no A.C. ripple. In Test (ii) the A.C. voltage must be sinusoidal.

TESTS

All tests to take place after the valve has been struck six times in the circuit shown in Fig.2.

	Test Conditions		Test	Limits		No. Tested	Note
	Vf(V)			Min.	Max.		
a	1.4	Va = Vg = 0	If (mA)		220	100%	
b	(Test in circuit Fig.2.) S2 closed. S1 open. Valve fired by opening S2.		Discharge test.	Valve must pass 35 mW seconds: G must read at least 15 divisions		100%	
c	1.4	(i) Test in circuit Fig.3. (ii) Test in circuit Fig.4.	"Vg" for striking (i) (V DC) (ii) (V RMS)	-3.0 2.1	-5.5 3.9	100%	C
d	Test 'c' repeated within 5 mins., change (+) in Vg for striking, from value in test 'c', observed.		Variation in "Vg" for striking. (i) (V DC) (ii) (V RMS)	- 0	0.4 0.28	100%	C
e	1.1 ← N.B.	Test 'c' repeated. Change in Vg for striking, from value in test 'c' observed.	Change of "Vg" with Vf (i) (V DC) (ii) (V RMS)	-	1.0	100%	C
				-	0.7		
f	Valve operated with Va = 135 V. through 0.1 Megohm Vf = 1.1 V. on for 60 seconds and off for 3 minutes successively. Va applied throughout, Vg set for non-striking. On/off cycle repeated at least 1000 times.		Life Test	Valve must pass tests 'a', 'b', 'c', 'd' and 'e' above at end of life run.		0.5% (5)	

FIG. 1

LEADS TO BE TINNED WITHIN 12.5 mm OF THE PINCH AND MUST BE NOT LESS THAN 1mm APART BETWEEN CENTRES AT POINT WHERE THEY LEAVE PINCH.

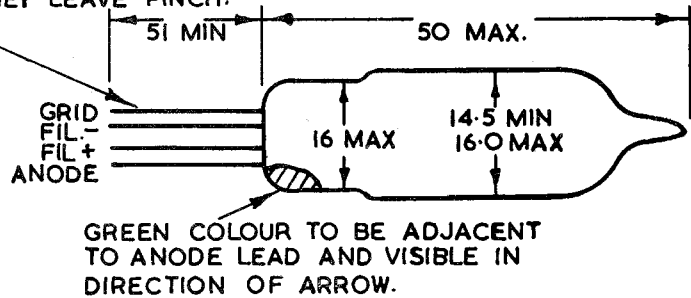

NOTE:- ALL DIMENSIONS IN MILLIMETRES.

FIG. 2

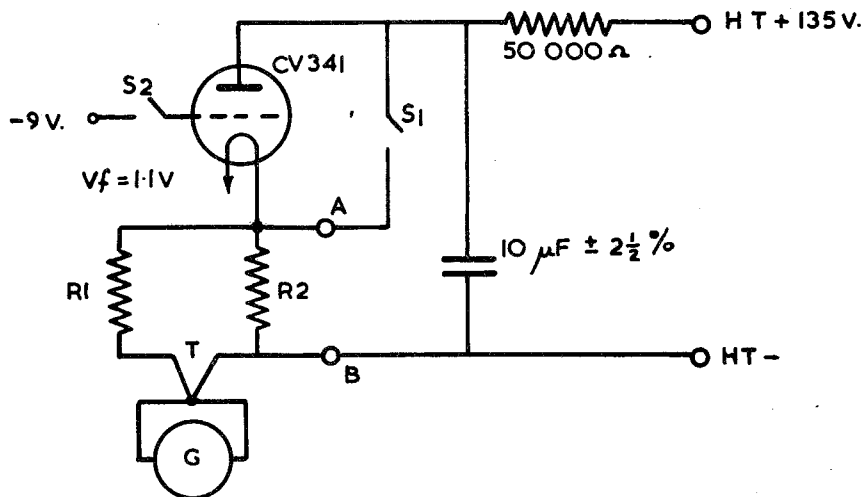

NOTES TO FIG. 2.

- T: THERMOCOUPLE
 G: GALVANOMETER, CALIBRATED SO THAT A DEFLECTION OF 40 DIVISIONS IS GIVEN BY DISCHARGE OF 10 μ F CONDENSER ON CLOSING SWITCH S1.
 S2: THIS SWITCH REMOVES GRID BIAS AND FIRES THE CV341.
 R1 & R2 ARE SUCH THAT THE RESISTANCE BETWEEN A & B WITH S1 OPEN IS $3\Omega \pm 2\frac{1}{2}\%$.

FIG. 3

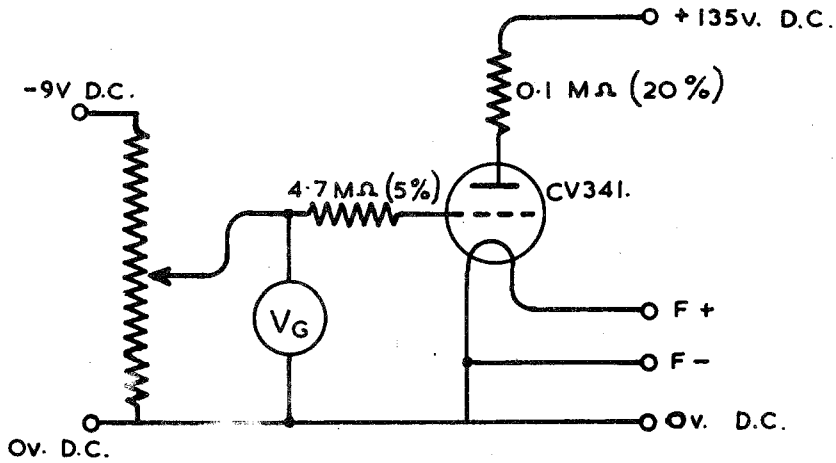

NOTE:- % TOLERANCES ON VALUES GIVEN IN FIG. 3 AND FIG. 4 ARE SHEWN IN BRACKETS.

FIG. 4

