

Specification MOS/CV513/Issue 4 Dated:- 11th November 1954 To be read in conjunction with K1001 ignoring clauses:- 5.2, 5.3, 5.8.		<u>SECURITY</u> <table border="1"> <tr> <td><u>Specification</u></td> <td><u>Valve</u></td> </tr> <tr> <td>Unclassified</td> <td>Unclassified</td> </tr> </table>		<u>Specification</u>	<u>Valve</u>	Unclassified	Unclassified														
<u>Specification</u>	<u>Valve</u>																				
Unclassified	Unclassified																				
<u>Type of valve:-</u> Magnetron <u>Cathode:-</u> Indirectly heated <u>Envelope:-</u> Metal-glass <u>Prototype:-</u> 4J53		<u>Marking</u> K. 1001/4 also Serial No.																			
<u>RATING</u>		<u>Base</u> None																			
<table border="1"> <thead> <tr> <th></th> <th></th> <th>NOTE</th> </tr> </thead> <tbody> <tr> <td>Heater Voltage</td> <td>(V) 16</td> <td>A</td> </tr> <tr> <td>Heater Current</td> <td>(A) 3</td> <td></td> </tr> <tr> <td>Frequency</td> <td>(Mc/s) 2793-2813</td> <td></td> </tr> <tr> <td>Max. Mean input power</td> <td>(W) 1200</td> <td>B</td> </tr> <tr> <td>Max. Frequency Pulling Figure</td> <td>(Mc/s) 15</td> <td></td> </tr> </tbody> </table>				NOTE	Heater Voltage	(V) 16	A	Heater Current	(A) 3		Frequency	(Mc/s) 2793-2813		Max. Mean input power	(W) 1200	B	Max. Frequency Pulling Figure	(Mc/s) 15		<u>Connections & dimensions</u> See pages 4 & 5 and Notes on page 6.	
		NOTE																			
Heater Voltage	(V) 16	A																			
Heater Current	(A) 3																				
Frequency	(Mc/s) 2793-2813																				
Max. Mean input power	(W) 1200	B																			
Max. Frequency Pulling Figure	(Mc/s) 15																				
<u>TYPICAL OPERATING CONDITIONS</u>		<u>Packaging</u>																			
<table border="1"> <tbody> <tr> <td>Peak anode voltage</td> <td>(kV) 21.5</td> <td rowspan="2">)A</td> </tr> <tr> <td>Peak anode current</td> <td>(A) 56</td> </tr> <tr> <td>Magnetic field strength</td> <td>(gauss) 2150</td> <td rowspan="2">)C</td> </tr> <tr> <td>Peak power output</td> <td>(kW) 600</td> </tr> <tr> <td>Duty cycle</td> <td>.0005</td> <td rowspan="2">)D</td> </tr> </tbody> </table>		Peak anode voltage	(kV) 21.5)A	Peak anode current	(A) 56	Magnetic field strength	(gauss) 2150)C	Peak power output	(kW) 600	Duty cycle	.0005)D	To the requirements of R. R. E. and in accordance with K1005						
Peak anode voltage	(kV) 21.5)A																			
Peak anode current	(A) 56																				
Magnetic field strength	(gauss) 2150)C																			
Peak power output	(kW) 600																				
Duty cycle	.0005)D																			
NOTES A-D. See page 3																					

CV513/4/1

Z.7703.R.

To be performed in addition to those applicable in K1001

	Test Conditions			Tests	Limits		No. Tested	Note
	V _h (V)	Mag field (gauss)	Mean I (mA)		Min.	Max.		
(a)	16	-	0	I _h (A)	2.8	3.4	100%	
(b)	13	2150	28	V _a (kV)	20	23	100%	1,2
(c)	"	+50	"	Power output (watts)	250		100%	1,2
(d)	"	"	"	Frequency (Mc/s)	2793	2813	100%	1,2
(e)	"	"	"	Spectrum width (Mc/s)		2.5	100%	1,2,4
(f)	"	"	"	Freq. pulling figure (Mc/s)		15	100%	1,2
(g)	10	2700	35	Stability (Mins)		5	100%	1,3,5
(h)	"	+50	"	Power output (watts)	400		T.A.	1,3
(i)	13	2150	28	Cold impedance			T.A.	1,2,6
		+50		V.S.W.R.	10			
				Posn. of V.S.W.Min.	10.7	12.0		

NOTES 1-6. See page 3

NOTES

- A. The heater should be switched on at least 3 mins. before the H.T. is applied.
- B. Cooling air shall be supplied sufficient to prevent the anode temperature exceeding 100°C.
- C. These figures are for operation with a pulse length of 1 usec. 500 p.p.s. and with a V.S.W.R. not worse than 0.67.
- D. During high voltage operation it is essential to operate the heater according to the following schedule.

<u>Power Input(watts)</u>	<u>Heater Voltage</u>	<u>Power Input(watts)</u>	<u>Heater Voltage</u>
1000-1200	8	600-800	13
800-1000	10.5	400-600	15
		400	16

This schedule is only valid for p.r.f.

300 p.p.s.

- The modulator used must be approved by R.R.E. It shall have a pulse length of 1 microsec. at 500 p.p.s. The magnetron shall feed into a coupling section in accordance with drawing on page 4. The waveguide load shall have a V.S.W.R. not worse than 0.9.
- The peak anode current shall be $56A \pm 10\%$.
- The peak anode current shall be $70A \pm 10\%$.
- To be carried out after a holding period of 168 hrs. during which the valve shall not have been operated.
- The heater supply shall be switched on for a period not exceeding 2 mins. before the H.T. is applied. The valve shall be considered to be operating stably when the average current is constant, showing no appreciable kicks, or by wide variations in the oscilloscope trace of input current or voltage. Stable operation shall be demonstrated over the last 30 secs. of a test period not to exceed 5 mins.
- This test to be made with a coaxial system coupled by means of the Test Coupling shown on Page 4. The position of the first V.S.W. minimum past the output coupling, measured from Reference Plane "C" on the outline drawing on Page 4, must lie within the limits shown.

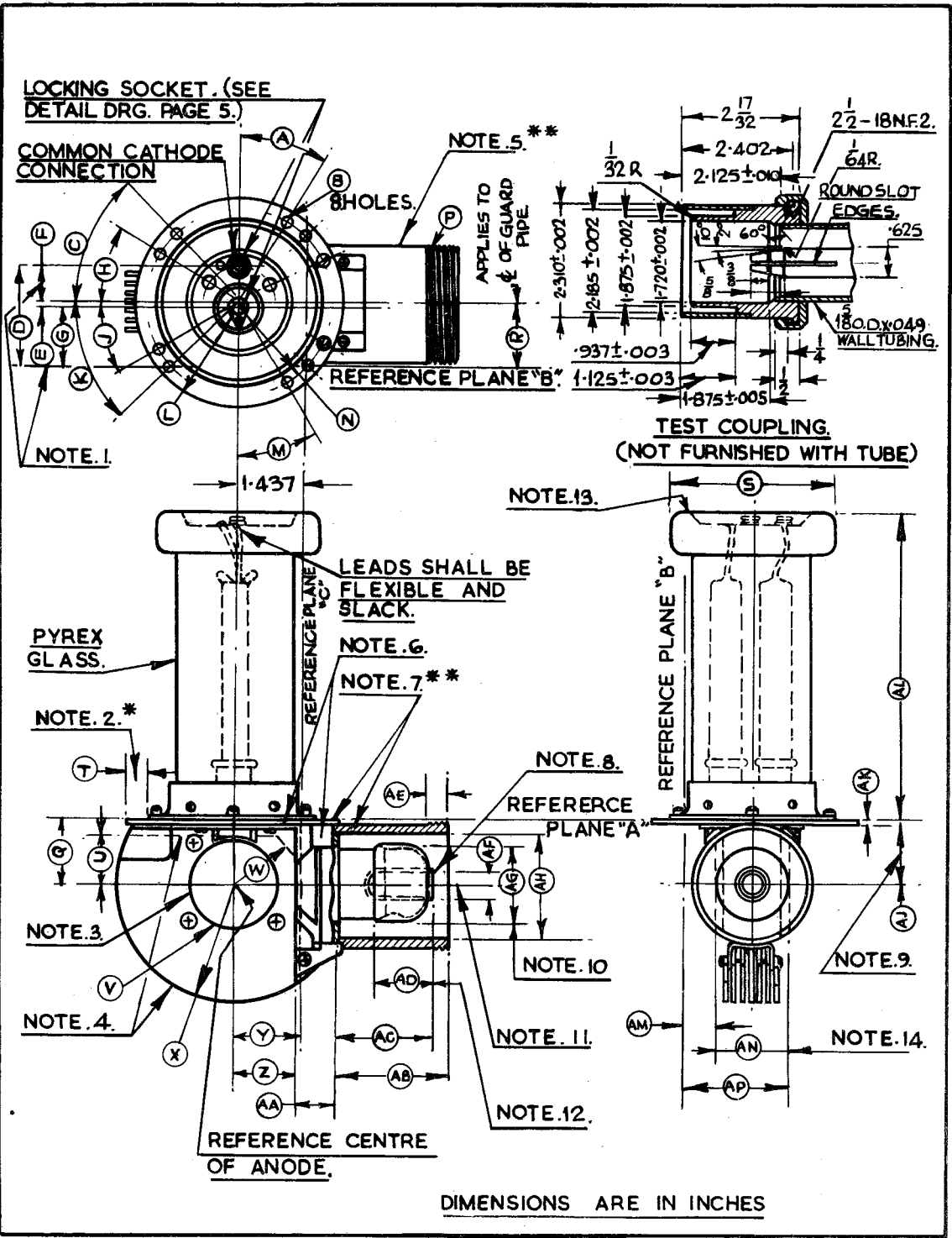

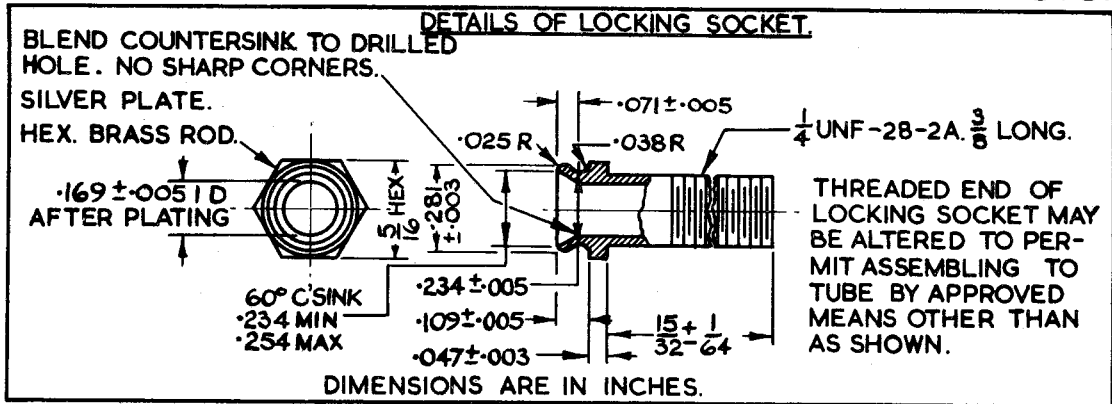

Ref.	Dimension	Ref.	Dimension	Ref.	Dimension
A**	30° ± 12'	P	2 1/2	AC	2.085 ± 0.025
B**	0.210 ± 0.005 Dia	Q	1.440	AD	1.125 Min.
C**	45° ± 12'	R	1.437 ± 0.020	AE	19/32 Min.
D	2.156	S**	3 17/32 Max.	AF	0.555 ± 0.015 I.D.
E	0.078	T**	1/2 Min.	AG	1.620 Max.
F	0.719	U**	1.063 Min.	AH	2.318 ± 0.004
G	1.359	V	2 1/32 Dia ± 3/32	AJ	1.440 ± 0.020
H**	30° ± 12'	W**	1 1/2 R Min.	AK***	3/16
J**	30° ± 12'	X**	2 2 1/32 R Max	AL**	6 5/16 ± 3/32
K**	45° ± 12'	Y**	1 1/2 Min.	AM	0.677 Min.
L**	2 9/32 ± 1/32 R	Z	1.437	AN	1.490 Max.
M**	30° ± 12'	AA**	0.818 ± 0.015	AP	2.197 Max.
N**	2.032 ± 0.003 R	AB	2.297 ± 0.010		

** To be checked on 1% (S) per batch

*** Type Approval only

NOTES (See Page 4)

1. The centre of the jack holes shall be within a radius of 0.100" of the location specified but shall be spaced 0.797" \pm 0.015" with respect to each other.
2. This annular area shall be flat within 0.015" (a thickness gauge $\frac{1}{8}$ " wide shall not enter more than $\frac{1}{4}$ ".)
3. The periphery of the anode shall lie within a 2.026" dia. circle located as specified.
4. Maximum width of 1.490" applies to area defined by dotted line and circumference of radiator.
5. Paint with black, heat-resistant, non-corrosive paint. The following shall be free from paint:- top surface of shield mounting plate, parts above shield mounting plate, screw threads on guard pipe and all surfaces inside guard pipe.
6. All solder or other joints on the output pipe shall provide hermetic seal.
7. Tube shall be supported by guard pipe or mounting flange.
8. No sharp edges on O.D. at end of inner conductor.
9. Applies to centre line of guard pipe.
10. Centre line of glass portion shall be concentric with centre line of guard pipe to within 0.040".
11. 0.555" \pm 0.015" applies to inner conductor insert only. Centre line of inner conductor insert shall be concentric with centre line of guard pipe to within 0.025".
12. Applies to straight portion of inner conductor wall.
13. Corona ring shall fall within a 3.662" diameter circle concentric with the circle passing through the centres of the 0.210" holes in the mounting plate.
14. Maximum width of 1.490" applies to area defined by dotted line and circumference of radiator.