

TUNG-SOL

TWIN TRIODE

MINIATURE BUTTON

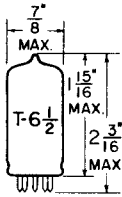

GLASS BULB

COATED UNIPOTENTIAL CATHODE

HEATER

SERIES	PARALLEL
12.6 VOLTS	6.3 VOLTS
0.15 AMP.	0.3 AMP.

AC OR DC

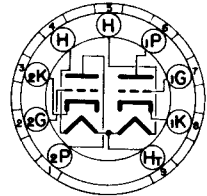

BOTTOM VIEW
MINIATURE BUTTON
9 PIN BASE

9A

FOR 12.6 VOLT OPERATION APPLY HEATER VOLTAGE BETWEEN PINS #4 AND #5. FOR 6.3 VOLT OPERATION APPLY HEATER VOLTAGE BETWEEN PIN #9 AND PINS #4 AND #5 CONNECTED TOGETHER.

ANY MOUNTING POSITION

THE 6189/12AU7WA IS A RUGGEDIZED, MEDIUM MU, TWIN TRIODE OF THE NINE PIN MINIATURE CONSTRUCTION. THE TWO TRIODE SECTIONS ARE ELECTRICALLY INDEPENDENT ALLOWING SIMULTANEOUS USE OF THE TWO IN WIDELY DIFFERENT APPLICATIONS. IN ADDITION TO GENERAL PURPOSE AUDIO FREQUENCY VOLTAGE AMPLIFIER AND PHASE INVERTER CIRCUITS, THE 6189/12AU7WA IS WELL SUITED TO USE AS OSCILLATOR, MULTIVIBRATOR, COMBINED OSCILLATOR-MIXER, AND RESISTANCE COUPLED AMPLIFIER SERVICE. THE HEATER CENTER TAP PERMITS OPERATION FROM EITHER A 6.3 OR 12.6 VOLT SUPPLY. CONTROLS ON THE PRODUCT AVERAGE FOR SUCH CHARACTERISTICS AS PLATE CURRENT TRANSCONDUCTANCE, AND AMPLIFICATION FACTOR ASSURE THAT THESE CRITICAL CHARACTERISTICS WILL REMAIN WELL CENTERED. SINCE IT MUST BE ABLE TO WITHSTAND SEVERE MECHANICAL TESTS TO MEET THE TEST SPECIFICATION, THE 6189/12AU7WA IS ESPECIALLY SUITED FOR USE IN INDUSTRIAL AND MILITARY AIRBORNE EQUIPMENT WHICH MAY BE SUBJECTED TO SEVERE SHOCK AND VIBRATION.

DIRECT INTERELECTRODE CAPACITANCES

	WITH SHIELD	WITHOUT SHIELD	
TRIODE UNIT #1			
GRID TO PLATE (RATED)	1.5	1.5	μμf
INPUT (RATED)	1.8	1.6	μμf
OUTPUT (RATED)	2.0	0.40	μμf
TRIODE UNIT #2			
GRID TO PLATE (RATED)	1.5	1.5	μμf
INPUT (RATED)	1.8	1.6	μμf
OUTPUT (RATED)	2.0	0.32	μμf

CONTINUED ON FOLLOWING PAGE

PRINTED IN U. S. A.

TUNG-SOL

CONTINUED FROM PRECEDING PAGE

RATINGS

ABSOLUTE MAXIMUM VALUES

HEATER VOLTAGE	6.3±10%	12.6±10%	VOLTS
MAXIMUM DC PLATE VOLTAGE	330		VOLTS
MAXIMUM PLATE DISSIPATION (PER PLATE)	3.0		WATTS
MAXIMUM HEATER CATHODE VOLTAGE	±200		VOLTS
MAXIMUM PEAK DC CATHODE CURRENT (EACH SECTION)	22		mA.
MAXIMUM BULB TEMPERATURE	165		°C

TYPICAL OPERATING CONDITIONS AND CHARACTERISTICS

CLASS A₁ AMPLIFIER - EACH TRIODE UNIT

HEATER VOLTAGE	12.6	6.3	12.6	6.3	VOLTS
HEATER CURRENT	0.15	0.3	0.15	0.3	AMP.
PLATE VOLTAGE	100		250		VOLTS
GRID VOLTAGE	0		-8.5		VOLTS
PLATE CURRENT	11.8		10.5		mA.
PLATE RESISTANCE (APPROX.)	6500		7700		OHMS
TRANSCONDUCTANCE	3100		2200		μMHOS
AMPLIFICATION FACTOR	20		17		
GRID VOLTAGE FOR I _b =10μA (APPROX.)	---		-24		VOLTS

RESISTANCE COUPLED AMPLIFIER

EACH SECTION

R _p MEG.	R _s MEG.	R _{g1} MEG.	E _{bb} = 90 VOLTS			E _{bb} = 180 VOLTS			E _{bb} = 300 VOLTS		
			R _k	GAIN	E _o	R _k	GAIN	E _o	R _k	GAIN	E _o
0.10	0.10	0.10	3300	14	13	2200	14	26	1800	14	40
0.10	0.24	0.10	3600	14	16	2700	15	33	2200	15	51
0.24	0.24	0.10	7500	14	16	5100	15	30	4300	15	44
0.24	0.51	0.10	9100	14	19	6800	15	39	5100	15	54
0.51	0.51	0.10	13000	14	16	9100	15	30	6800	16	40
0.51	1.0	0.10	15000	14	19	10000	16	32	7500	16	45
0.24	0.24	10	0	15	13	0	16	33	0	17	46
0.24	0.51	10	0	16	17	0	17	38	0	18	62
0.51	0.51	10	0	16	14	0	18	32	0	18	53
0.51	1.0	10	0	17	18	0	18	41	0	19	68

- NOTES:**
1. E_o IS MAXIMUM RMS VOLTAGE OUTPUT FOR FIVE PERCENT (5%) TOTAL HARMONIC DISTORTION.
 2. GAIN MEASURED AT 2.0 VOLTS RMS OUTPUT.
 3. FOR ZERO-BIAS DATA, GENERATOR IMPEDANCE IS NEGLIGIBLE.

TUNG-SOL

CONTINUED FROM PRECEDING PAGE

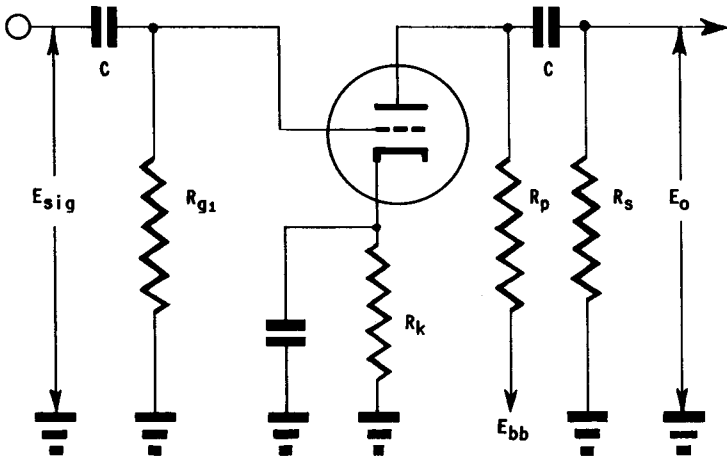

NOTES: COUPLING CAPACITORS (C) SHOULD BE SELECTED TO GIVE DESIRED FREQUENCY RESPONSE.
 R_k SHOULD BE ADEQUATELY BY-PASSED.

CHARACTERISTICS RANGE VALUES FOR EQUIPMENT DESIGN

$E_f=12.6V, E_b=250Vdc, E_c=-8.5Vdc$

EXCEPT AS MODIFIED BELOW

	INITIAL				500 HOUR LIFE TEST		
	INDIVIDUAL MIN.	MAX.	PROD. MIN.	AVG. MAX.	INDIVIDUAL MIN.	MAX.	
HEATER CURRENT	138	162	---	---	138	162	mA.
HEATER CATHODE LEAKAGE ^A ($E_{hk}=\pm 100Vdc$)	---	± 10	---	---	---	± 10	μAdc
GRID CURRENT (1) ($R_g=0.5$ MEG.)	0	-0.5	---	---	0	-0.5	μAdc
PLATE CURRENT (1)	6.5	14.5	9.0	12.0	---	---	mAdc
TRANSCONDUCTANCE (1)	1750	2650	2000	2400	1600	2650	$\mu MHOS$
Δ AVERAGE TRANSCONDUCTANCE (1)	---	---	---	---	---	15	PERCENT
INSULATION OF ELECTRODES ^B ($E_f=12.6V, E(g-a11)=100Vdc, g$ NEG.: $E(p-a11)=300Vdc, p$ NEG.)							
$R(g-a11)$	500	---	---	---	250	---	MEGOHMS
$R(p-a11)$	500	---	---	---	250	---	MEGOHMS
PLATE CURRENT (2) ($E_c=-25Vdc$)	---	20	---	---	---	---	μAdc
PLATE CURRENT (3) ($E_c=-18Vdc$)	---	5	---	---	---	---	μAdc
Δ TRANSCONDUCTANCE (2) ^C	---	15	---	---	---	15	PERCENT
GRID CURRENT (2) ^D	0	-1.5	---	---	---	---	μAdc
PLATE CURRENT (1) (DIFFERENCE BETWEEN SEC.)	---	3.5	---	---	---	---	mAdc
TRANSCONDUCTANCE (3) ($E_b=100Vdc, E_c=0$)	2500	4000	2850	3650	---	---	$\mu MHOS$
AMPLIFICATION FACTOR	15.5	18.5	16.2	17.8	---	---	

CONTINUED ON FOLLOWING PAGE

PRINTED IN U. S. A.

PREMIUM TUBE

TUNG-SOL

CONTINUED FROM PRECEDING PAGE

SPECIAL REQUIREMENTS

	MIN.	MAX.	
RF NOISE AEF (Ec=-9Vdc, Eca1=7.0mVac) NOISE AND MICROPHONICS AGH	---	3.0	mW.
(Ef=12.6Vac, Ehk=0, Ebb=300Vdc, Ec=0, Rp=50,000)	---	50	mVac
LOW FREQUENCY VIBRATION JA (Rp=2000)	---	100	mVac
LOW PRESSURE VOLTAGE BREAKDOWN K	500	---	Vac
STABILIZATION INTERMITTENT LIFE TEST CONDITIONS OR EQUIVALENT	---	---	
VARIABLE FREQUENCY VIBRATION LA (Rp=2000)	---	100	mVac
VIBRATIONAL FATIGUE M	---	---	
SHOCK N (HAMMER ANGLE=30°; Ehk=400Vdc, HEATER POSITIVE; Rg=0.1MEG.)	---	---	
POST SHOCK AND FATIGUE TEST END POINTS			
LOW FREQUENCY VIBRATION	---	150	mVac
HEATER-CATHODE LEAKAGE	---	±30	μAdc
TRANSCONDUCTANCE {3}	2000	---	μMHOS
GRID CURRENT {1}	0	-1.5	μAdc
SHORT AND CONTINUITY P	---	---	
GLASS STRAIN R	---	---	

NOTES

- A THE 1p TO 2p, 1g TO 2g, 1k TO 2k. (PARASITIC SUPPRESSORS OF 50 OHMS MAXIMUM ARE PERMITTED).
- B SEE MIL-E-1C 4.8
- C THE VALUE OF TRANSCONDUCTANCE (2) SHALL APPLY TO INDIVIDUAL TUBES AND IS EXPRESSED:--

$$\frac{(Sm \text{ AT } 12.6) - (Sm \text{ AT } 11.4)}{(Sm \text{ AT } 12.6)} \times 100$$
- E SEE MIL-E-1C 4.10.3.1
- F THE OUTPUT INDICATOR SHALL BE A "VU" METER. THE THREE (3) MILLIWATT POINT SHALL BE DETERMINED AS A METER DEFLECTION OF 25 PERCENT THE CALIBRATION POINT.
- G THE CATHODE RESISTOR SHALL BE SHUNTED WITH A CAPACITIVE REACTANCE NOT EXCEEDING THREE (3) OHMS AT 60 CYCLES.
- H TIE CATHODES TOGETHER AND GROUND THROUGH A 1500 OHM RESISTOR. GRIDS ARE GROUNDING.
- J SEE MIL-E-1C 4.9.20.4
- K BREAKDOWN SHALL BE DEFINED AS THE VOLTAGE AT WHICH ARCING OCCURS BETWEEN ANODE BASE PIN AND ADJACENT PINS. PRESSURE=55±5mmHg.; TEMPERATURE=25±5°C; HUMIDITY=0; VOLTAGE=500vac, 60 CYCLES, SINUSOIDAL WAVE FORM.
- L SEE MIL-E-1C 4.9.20.3
- M SEE MIL-E-1C 4.9.20.6
- N SEE MIL-E-1C 4.9.20.5
- P SEE MIL-E-1C 4.7.5
- R GLASS STRAIN TEST CONSISTS OF COMPLETELY SUBMERGING THE TUBE INTO BOILING WATER (97°C-100°C) FOR A PERIOD OF 15 SECONDS, THEN IMMEDIATELY PLUNGING INTO COLD WATER (0±3°C). THE AMOUNT OF WATER SHALL BE AT LEAST TWO (2) LITERS PER FIFTEEN TUBES. TUBES FOR THIS TEST SHALL HAVE BEEN EXHAUSTED A MINIMUM OF 48 HOURS PRIOR TO PERFORMANCE OF THIS TEST.
- D PRIOR TO THIS TEST TUBES TO BE PREHEATED FIVE (5) MINUTES AT CONDITIONS INDICATED BELOW. TEST IMMEDIATELY AFTER PREHEATING Ef=14.0V, Ec=-8.5Vdc, Rk=0 OHMS, Eb=250Vdc, Rg=0.5 MEG.

